



**ModulA... RED, ModulA-D... RED,  
ModulA... BLUE**

**T2 M/L**

**Installation and Operating Instructions** (Seite 6)

**Montage- en bedrijfsinstructies** (Pagina 36)

**Instrucciones de montaje y funcionamiento** (Página 66)

**EN Declaration of Conformity**

We Biral AG declare under our sole responsibility that the products

**ModulA... RED, ModulA-D... RED**

**ModulA... BLUE**

to which this declaration relates, are in conformity with the Council Directives on the approximation of the laws of the EC Member States relating to:

- Machinery (2006/42/EG) Standard: 12100-1:2010
- Electrical equipment designed for use within certain voltage limits (2014/35/EU) Norms: EN 60335-1:2012, EN 60335-2-51:2003 + A1:2008 + A2:2012
- Electromagnetic compatibility (2014/30/EU) Norms: EN 61000-6-2:2005, EN 61000-6-3:2007
- Only for types marked with the EEI. (See the pump nameplate):  
Ecodesign (2009/125/EC) Circulator Pumps Commission Regulation No 641/2009 Standards: EN 16297-1:2012, EN16297-2:2012

**NL Conformiteitverklaring**

Wij Biral AG verklaren geheel onder eigen verantwoordelijkheid dat de producten

**ModulA... RED, ModulA-D... RED**

**ModulA... BLUE**

waarop deze verklaring betrekking heeft in overeenstemming zijn met de Richtlijnen van de Raad inzake de onderlinge aanpassing van de wetgevingen van de EG Lid-Staten betreffende

- Machines (2006/42/EG) Norm: EN 12100-1:2010
- Elektrisch materiaal voor gebruik binnen bepaalde spanningsgrenzen (2014/35/EU) Normen: EN 60335-1:2012, EN 60335-2-51:2003 + A1:2008 + A2:2012
- Elektromagnetische compatibiliteit (2014/30/EU) normen: EN 61000-6-2:2005, EN 61000-6-3:2007
- Ecodesign (2009/125/EC)  
Circulatiepompen: Verordening nr. 641/2009 van de Commissie. Normen: EN 16297-1:2012, EN 16297-2:2012 (geldt alleen voor types die met de ETI zijn gemarkeerd. EEI staat voor Energy Efficiency Index, zie bedrijfsnaamplaatje).

**ES Declaración de conformidad**

Nosotros Biral AG declaramos bajo nuestra única responsabilidad que los productos

**ModulA... RED, ModulA-D... RED**

**ModulA... BLUE**

son conformes con las Directivas del Consejo relativas a la aproximación de las legislaciones de los Estados Miembros de la CE sobre

- Máquinas (2006/42/CE)  
Norma: EN 12100-1: 20101
- Material eléctrico destinado a utilizarse con determinadas límites de tensión (2014/35/EU)  
Normas: EN 60335-1:2012, EN 60335-2-51:2003 + A1:2008 + A2:2012
- Compatibilidad electromagnética (2014/30/EU)  
Normas: EN 61000-6-2:2005, EN 61000-6-3:2007
- Únicamente a las circuladoras marcadas con el EEI. (Véase la placa de características):  
Diseno ecológico (2009/125/EC)  
Bombas circuladoras: Reglamento de la Comisión no 641/2009. Normas: EN 16297-1:2012, EN16297-2:2012

Münsingen, 1<sup>st</sup> April 2020



Roger Steuri  
Head of Product Development/Management

Person authorised to compile technical file and empowered to sign the EC declaration of conformity.

**Biral AG**

Südstrasse 10  
CH-3110 Münsingen  
Phone +41 31 720 90 00  
Fax +41 31 720 90 10  
info@biral.ch  
www.biral.ch

Dimensions Afmetingen Dimensiones	Series Serie Series								
	ModuA... RED ModuA... BLUE								
	32F-12 220 PN 6-16	40-8 220 PN 6-16	40-10 220 PN 6-16	40-12 250 PN 6-16	40-18 250 PN 6-16	50-6 240 PN 6-16	50-6 270 PN 6-16	50-8 240 PN 6-16	50-12 270 PN 6-16
DN	32	40	40	40	40	50	50	50	50
L1	220	220	220	250	250	240	270	240	270
B1	144.6	147.5	147.5	153.8	153.8	160.4	166.9	160.4	166.9
B2	72.3	72.3	72.3	72.3	72.3	72.1	74.4	72.1	74.4
B3	163.5	163.5	163.5	163.5	163.5	163.5	163.5	163.5	163.5
B4	105	105	105	105	105	105	105	105	105
D	140	150	150	150	150	165	165	165	165
k1 (PN 6)	90	100	100	100	100	110	110	110	110
k2 (PN 10/16)	100	110	110	110	110	125	125	125	125
d	4x14/19	4x14/19	4x14/19	4x14/19	4x14/19	4x14/19	4x14/19	4x14/19	4x14/19
T1	365.5	368.4	368.4	368.4	368.4	373.5	375	373.5	375
T2	55.6	59	59	62	62	64	64	64	64
T3	300.5	303.4	303.4	303.4	303.4	303	303	303	303
T4	86	86	86	86	86	97	97	97	97
kg (RED)	15.3	16.3	16.3	16.1	16.1	17.6	18.1	17.6	18.1
kg (BLUE)	-	-	-	18.1	18.1	-	-	-	-

	50-18 270 PN 6-16	65-8 270 PN 6-16	65-8 340 PN 6-16	65-12 340 PN 6-16	65-15 340 PN 6-16				
DN	50	65	65	65	65				
L1	270	270	340	340	340				
B1	166.9	184	184	184	184				
B2	74.4	82	82	82	82				
B3	163.5	163.5	163.5	163.5	163.5				
B4	105	120	120	120	120				
D	165	185	185	185	185				
k1 (PN 6)	110	130	130	130	130				
k2 (PN 10/16)	125	145	145	145	145				
d	4x14/19	4x14/19	4x14/19	4x14/19	4x14/19				
T1	375	391.5	384.9	384.9	384.9				
T2	64	62.1	68.7	68.7	68.7				
T3	303	317.5	310.9	310.9	310.9				
T4	97	90	96	96	96				
kg (RED)	18.8	20.6	24	21.5	24				

Dimensions Afmetingen Dimensiones	Series Serie Series							
	ModulA... RED							
	80-8 360 PN 6	80-8 360 PN 10-16	80-12 360 PN 6	80-12 360 PN 16	100-8 450 PN 6	100-8 450 PN 16	100-12 450 PN 6	100-12 450 PN 16
<b>DN</b>	80	80	80	80	100	100	100	100
<b>L1</b>	360	360	360	360	450	450	450	450
<b>B1</b>	219.6	219.6	219.6	219.6	223.2	223.2	223.2	223.2
<b>B2</b>	97	97	97	97	98.4	98.4	98.4	98.4
<b>B3</b>	163.5	163.5	163.5	163.5	163.5	163.5	163.5	163.5
<b>B4</b>	126	126	126	126	126	126	126	126
<b>D</b>	200	200	200	200	220	220	220	220
<b>k1 (PN 6)</b>	150	–	150	–	170	–	170	–
<b>k2 (PN 10/16)</b>	–	160	–	160	–	180	–	180
<b>d</b>	4x19	8x19	4x19	8x19	4x19	8x19	4x19	8x19
<b>T1</b>	411.9	411.9	411.9	411.9	432.2	432.2	432.2	432.2
<b>T2</b>	82.7	82.7	82.7	82.7	80.6	80.6	80.6	80.6
<b>T3</b>	317.9	317.9	317.9	317.9	330.2	330.2	330.2	330.2
<b>T4</b>	108.6		108.6	108.6	113.4	113.4	113.4	113.4
<b>kg</b>	29.1	29.1	29.1	29.1	34	34	34	34

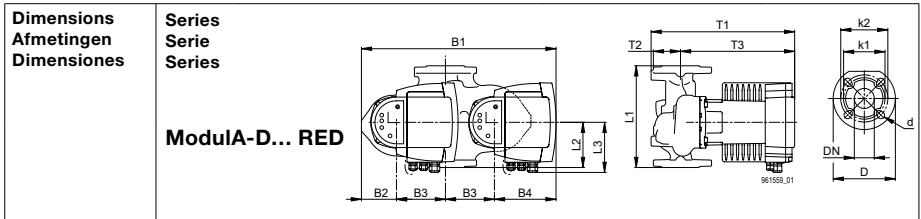

	32F-12 220 PN 6-16	40-8 220 PN 6-16	40-10 220 PN 6-16	40-12 250 PN6-16	40-18 250 PN6-16	50-6 240 PN6-16	50-8 240 PN 6-16	50-12 270 PN6-16	50-18 270 PN6-16	65-8 340 PN6-16
<b>DN</b>	32	40	40	40	40	50	50	50	50	65
<b>L1</b>	220	220	220	250	250	240	240	270	270	340
<b>B1</b>	504	505	505	512	512	515	515	517	517	522
<b>B2</b>	80	81	81	88	88	91	91	93	93	98
<b>B3</b>	130	130	130	130	130	130	130	130	130	130
<b>B4</b>	164	164	164	164	164	164	164	164	164	164
<b>D</b>	140	150	150	150	150	165	165	165	165	185
<b>k1 (PN6)</b>	90	100	100	100	100	110	110	110	110	130
<b>k2 (PN10/16)</b>	100	110	110	110	110	125	125	125	125	145
<b>d1</b>	4x14/19	4x14/19	4x14/19	4x14/19	4x14/19	4x14/19	4x14/19	4x14/19	4x14/19	4x14/19
<b>L2</b>	130	120	120	115	115	125	125	120	120	140
<b>L3</b>	133	133	133	133	133	133	133	133	133	133
<b>T1</b>	373	382	382	376	376	383	383	381	381	391
<b>T2</b>	65	65	65	65	65	71	71	72	74	74
<b>T3</b>	301	304	304	304	304	303	303	303	311	311
<b>kg</b>	31	31	31	32	32	35	35	36	36	42

	65-12 340 PN6-16	65-15 340 PN6-16	80-8 360 PN6	80-8 360 PN10/16	80-12 360 PN6	80-12 360 PN10/16	100-8 450 PN6	100-8 450 PN10/16	100-12 450 PN6	100-12 450 PN10/16
<b>DN</b>	65	65	80	80	80	80	100	100	100	100
<b>L1</b>	340	340	360	360	360	360	450	450	450	450
<b>B1</b>	522	522	538	538	538	538	546	546	546	546
<b>B2</b>	98	98	114	114	114	114	122	122	122	122
<b>B3</b>	130	130	130	130	130	130	135	135	135	135
<b>B4</b>	164	164	164	164	164	164	164	164	164	164
<b>D</b>	185	185	200	200	200	200	220	220	220	220
<b>k1 (PN 6)</b>	130	130	150	-	150	-	170	-	170	-
<b>k2 (PN10/16)</b>	145	145	-	160	-	160	-	180	-	180
<b>d1</b>	4x14/19	4x14/19	4x19	8x19	4x19	8x19	4x19	8x19	4x19	8x19
<b>L2</b>	140	140	160	160	160	160	190	190	190	190
<b>L3</b>	133	133	133	133	133	133	133	133	133	133
<b>T1</b>	391	391	418	418	418	418	436	436	436	436
<b>T2</b>	74	74	94	94	94	94	99	99	99	99
<b>T3</b>	311	311	318	318	318	318	330	330	330	330
<b>kg</b>	42	48	58	58	58	58	68	68	68	68

# Contents

<b>1</b>	<b>Safety information.....7</b>		
1.1	General remarks .....7	5.5.1	Switch 1, Fault or operating signal (switchable).....21
1.2	Identification of notices .....7	5.5.2	Switch 2, external OFF or external ON (switchable).....22
1.3	Staff qualification and training.....7	5.5.3	Switch 3, power limit (can be activated).....22
1.4	Risks in the event of non-compliance with the safety information .....7		
1.5	Safety-conscious work .....7	<b>6</b>	<b>Start-up.....23</b>
1.6	Safety information for the operator/ operating personnel.....8	6.1	General .....23
1.7	Safety information for installation, maintenance and inspection works .....8	6.2	Operational control .....23
1.8	Unauthorised reconstruction and production of spares.....8	<b>7</b>	<b>Settings.....23</b>
1.9	Improper operating methods .....8	7.1	Control panel .....23
<b>2</b>	<b>Symbols used.....8</b>	7.2	Types of control .....24
<b>3</b>	<b>General information.....9</b>	7.3	Delivery height (A2) .....24
3.1	Purpose .....9	7.4	Display of the current delivery height (LED $\checkmark$ ) .....25
3.2	Requirements of the delivery medium....9	7.5	Summary of maximum delivery height and delivery amount .....25
3.3	Operating conditions .....10	7.6	Activating/deactivating the control keys .....25
3.4	Non-return valve .....11	7.7	START/STOP pump .....25
3.5	Protection from the effects of frost.....12	7.8	Activate/deactivate dry running detection.....26
3.6	Heat insulation (ModulA... RED, ModulA... BLUE) .....12	7.9	Bluetooth (Biral ONE.) .....27
3.7	Flow direction .....12	7.9.1	Activate Bluetooth.....27
<b>4</b>	<b>Installation.....13</b>	7.9.2	Open Biral ONE. ....27
4.1	General notes .....13	7.9.3	Extract Biral ONE.....27
4.2	Flushing heating equipment (for extended pump).....13	7.10	Biral impeller .....28
4.3	Installation.....13	7.11	On-site adjustment of the pump .....28
4.4	Permissible installation positions .....13	<b>8</b>	<b>Fault summary and checklist .....29</b>
4.5	Changing the installation position of the frequency converter.....14	<b>9</b>	<b>Sensor.....31</b>
4.5.1	Rotate the pump head ModulA M.....15	<b>10</b>	<b>Accessories/versions .....31</b>
4.5.2	Rotate the pump head ModulA L.....15	10.1	Biral interface module, BIM B3 .....31
4.6	Install the pump in the unit.....17	10.2	Building set for recessed installation of electronics .....31
4.6.1	Flange connection .....17	10.3	Cold water pump version.....31
<b>5</b>	<b>Electrical connection.....18</b>	10.4	Blind flange.....32
5.1	Additional safety features.....18	<b>11</b>	<b>Technical data.....32</b>
5.2	Supply voltage .....18	<b>12</b>	<b>Recycling .....33</b>
5.3	Connection of the power supply .....19	<b>13</b>	<b>Spare parts list .....34</b>
5.4	Connection drawing Clamp description.....20		
5.5	Switch settings .....21		

# 1 Safety information



## Warning

This product may only be installed and used by people who have adequate knowledge and experience. People with limitations in their physical or mental capacity or sensory perception, may not use the product, unless they have been sufficiently trained by a person who is responsible for their safety.

The product must be kept out of the reach of children. The product must not be used by children, e.g. as a toy.

### 1.1 General remarks

These installation and operating instructions contain items of information of fundamental importance which must be taken into account during assembly, operation and maintenance. They should therefore be read without fail before installation and commissioning by the fitter and also the responsible specialist staff/operator. They must always be available for consultation at the plant's place of deployment. Not only are the general safety hints included in this «Safety Hints» section to be observed, but also the special items of safety information included in the other sections.

### 1.2 Identification of notices

Information signs mounted directly on the plant, such as, for example

- rotating direction arrow
- symbols for fluid connections

must be obeyed without fail and be kept in a fully legible state.

### 1.3 Staff qualification and training

The staff deployed for assembly, operating, maintenance and inspection tasks must show that they have the appropriate qualifications for such work. The field of responsibility, competence and supervision of the staff must be stipulated exactly by the operator.

### 1.4 Risks in the event of non-compliance with the safety information

Non-compliance with the safety information can result in both danger for persons and also for the plant and the environment. Non-compliance with the safety information can lead to the loss of claims for damages of any kind. In detail, non-compliance, for example, may result in the following risks:

- failure of important functions in the plant
- failure of prescribed methods for servicing and maintenance
- danger to persons through electrical and mechanical causes

### 1.5 Safety-conscious work

The safety information contained in these installation and operating instructions, the existing national regulations for the prevention of accidents, as well as any internal working, operating and safety regulations stipulated by the operator must be observed.

### 1.6 Safety information for the operator/operating personnel

Any risks from electric power must be eliminated (For details see, for example, the regulations published by NIN (CENELEC) and the I.E.E.).

### 1.7 Safety information for installation, maintenance and inspection works

The operator has to ensure that all installation, maintenance and inspection works are carried out by authorised and qualified specialist personnel who have informed themselves adequately about the requirements by a thorough study of the installation and operating instructions.

Basically, any works on the plant should only be carried out when it is at a standstill and not carrying any electrical current. Directly after completion of the works, all safety and protective installations must be mounted or activated again.

Before re-commissioning, the points listed in the section «Electrical connection» must be observed.

### 1.8 Unauthorised reconstruction and production of spares

Reconstruction of or changes to pumps are only permissible after consultation with the manufacturer. Genuine spare parts and accessories authorised by the manufacturer serve the cause of safety. The use of other parts can cancel any liability for the resultant consequences of this.

### 1.9 Improper operating methods

The operating reliability of the pumps supplied is only guaranteed with appropriate application of the section «Intended application» of the Installation and Operating Instructions. The limit values given in the technical data must not be exceeded on any account.

## 2 Symbols used



#### Warning

Serious personal injury may result from not adhering to these safety notes.



#### Warning

Danger from dangerous electrical voltage.

If these safety instructions are not adhered to, there is a risk of electric shock, which may lead to serious injury or death.



#### Warning

Risk of injury or burns from hot surfaces!



#### Warning

Risk of injury from falling objects!





### Warning

Risk of injury from escaping steam!



Not adhering to these safety notes may cause malfunctioning or material damage.



This contains advice or notes that facilitate work and ensure safe operation.

## 3 General information

The Biral series, ModulA consists of a complete range of circulation pumps with integrated frequency converter, which enable independent or controlled adaptation of output to the actual requirement of each system. Therefore, in many systems, energy consumption will be reduced and the control behaviour of the system improved. Besides this, current noise from control cabinets can be reduced effectively. All necessary settings can be adjusted using the control panel for the pump.

### 3.1 Purpose

Biral circulation pumps of the ModulA series are intended for the circulation of liquids in the following systems:

- ModulA... RED in heating units
- ModulA... BLUE in domestic hot water systems

The pumps can also be used in the following systems:

- Geothermal heat pumps
- Thermal solar equipment

The pumps are suitable for use in systems with variable and constant delivery volumes.

### 3.2 Requirements of the delivery medium

The pump is suitable for delivery of pure, thin, non-explosive and non-aggressive media without fixed or long-fibred elements, which do not affect the pump either mechanically or chemically.

#### Heating water:

Requirements according to current standards that apply to water quality in heating systems: (e.g. VDI 2035)

**Glykol:**

The pump can be used for delivering water-glycol mixes. Maximum permissible viscosity: 50 mm<sup>2</sup>/s (cSt). This corresponds to a water-ethylene-glycol mix with a glycol content of around 50% at -10°C. The pump is controlled via an output-limiting function that protects against overload. The delivery of glycol mixes affects the MAX characteristic curve because the delivery capacity is reduced accordingly, based on the glycol content and temperature of the media. So that the effect of the glycol is not reduced, temperatures above the nominal temperature given for the medium should be avoided. Generally, the operating duration with high media temperatures should be minimised. Before adding the glycol mix, it is vital that the system is cleaned and rinsed. To avoid corrosion or precipitations, the glycol mix should be checked regularly and changed if necessary. If the glycol mix has to be further thinned, the specifications from the glycol manufacturer should be adhered to.



For the delivery of a liquid with density that differs from water and/or kinematic viscosity, the delivery output is reduced.

**Domestic hot water:**

Permissible water hardness:

max. 35 °fH (20 °dH) (water temperature below 65 °C)

max. 25 °fH (14 °dH) (water temperature below 85 °C)

To counter the risk of lime deposits, for domestic hot water systems we recommend:

Hardness level max. 25 °fH (14 °dH) Medium temperature <65 °C

**Warning**

The pump may not be used to deliver combustible media such as diesel and fuel.

**Warning**

The pump may not be used to deliver aggressive liquids such as acids or seawater.

**3.3 Operating conditions****Medium temperature:**

- Modula... RED +15 °C to +110 °C

- Modula... BLUE +15 °C to +85 °C (recommended for domestic hot water systems: max 65 °C)

**Operating pressure:**

The maximum permissible operating pressure is indicated on the nameplate. (6 bar, 10 bar or 16 bar) Minimum operating pressure at the pump intake ports (intake pressure) at 500 m above sea level:

ModulA...	Medien temperature		
	75 °C	95 °C	110 °C
	Supply pressure [bar]		
ModulA 32F-12 220	0.1	0.35	1.0
ModulA 40-8 220	0.1	0.50	1.0
ModulA 40-10 220	0.1	0.50	1.0
ModulA 40-12 250	0.1	0.50	1.0
ModulA 40-18 250	0.1	0.50	1.0
ModulA 50-6 240	0.1	0.40	1.0
ModulA 50-6 270	0.1	0.40	1.0
ModulA 50-8 240	0.1	0.40	1.0
ModulA 50-12 270	0.1	0.50	1.0
ModulA 50-18 270	0.7	1.20	1.7
ModulA 65-6 270	0.7	1.20	1.7
ModulA 65-8 270	0.7	1.20	1.7
ModulA 65-8 340	0.7	1.20	1.7
ModulA 65-12 340	0.7	1.20	1.7
ModulA 65-15 340	0.7	1.20	1.7
ModulA 80-8 360	0.5	1.00	1.5
ModulA 80-12 360	0.5	1.00	1.5
ModulA 100-8 450	0.7	1.20	1.7
ModulA 100-12 450	0.7	1.20	1.7

Per ±100 m height ± 0.01 bar

In the dual pump operation the supply pressure required must be increased by 0.1 bar in line with the values in the table.

**Ambient temperature:**

0 °C to 40 °C

**3.4 Non-return valve**

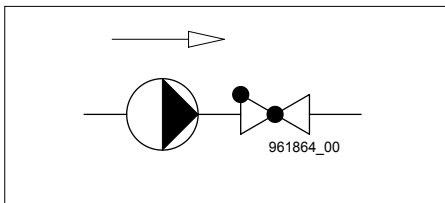

If a non-return valve is fitted, the pump must be adjusted (see 7.2), so that the discharge pressure of the pump exceeds the closing pressure of the valve at all times.

This must be adhered to in particular for the proportional pressure control (reduced delivery height for decreasing delivery flow).

### 3.5 Protection from the effects of frost



Where there is a risk of frost during downtime periods, measures required to avoid frost damage must be taken.

### 3.6 Heat insulation (ModulA... RED, ModulA... BLUE)



Heat is lost via the pump casing and pipes. These heat losses should be limited to a minimum.

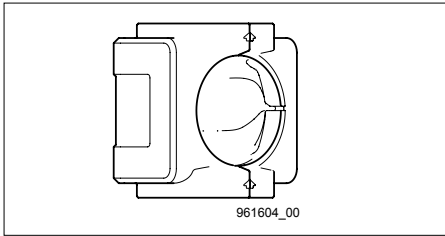

Heat losses can be reduced by insulating the pump casing and pipes.

For ModulA... RED, heat insulation shells are included in the delivery.

Heat insulation shells can only be supplied for single pumps

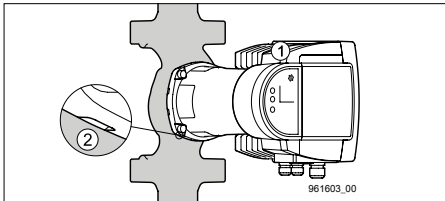

- ① Never cover the frequency converter or the control panel with insulation.
- ② Keep the drainage outlet at the motor free..

### 3.7 Flow direction

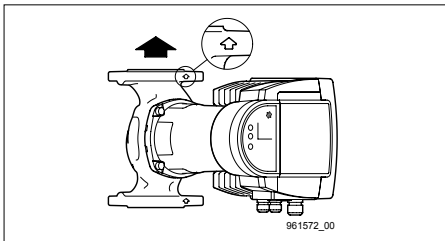

The arrow on the pump casing indicates the flow direction.

## 4 Installation

### 4.1 General notes

ModulA is only intended for installation indoors. The pumps must be mounted voltage-free so that no energy can be transferred from the pipes to the pump casing. The pumps can be installed directly in the pipe, provided the pipes are designed for the weight of the pump.

Installation is only possible after completion of all welding and soldering work on the system. Avoid drops of water on the pump motor, especially the frequency converter.



#### Warning

The local regulations for the lifting and carrying of loads must be adhered to. The weight of the pump is given on the packaging.

### 4.2 Flushing heating equipment (for extended pump)

To avoid unwanted interruptions to operations and non-running of the pump after longer periods of inactivity, we recommend thoroughly flushing out the equipment following the new installation or adaptation of heating and refilling.

The equipment must correspond with the latest technology. (Placement of expansion vessel or safety flow).

### 4.3 Installation

Install only after completion of all welding or soldering work on the equipment. Water drops should be avoided on the pump motor, especially on the electronics. The pump casing should be installed voltage-free in the equipment.

### 4.4 Permissible installation positions

The installation position of the rotor shaft must always be horizontal.

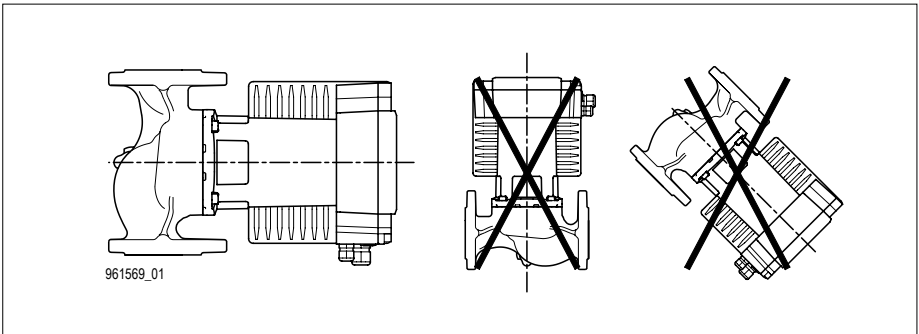

To guarantee adequate cooling, the frequency converter must always be in a horizontal position. (A, B, C, D). It is delivered in position A.

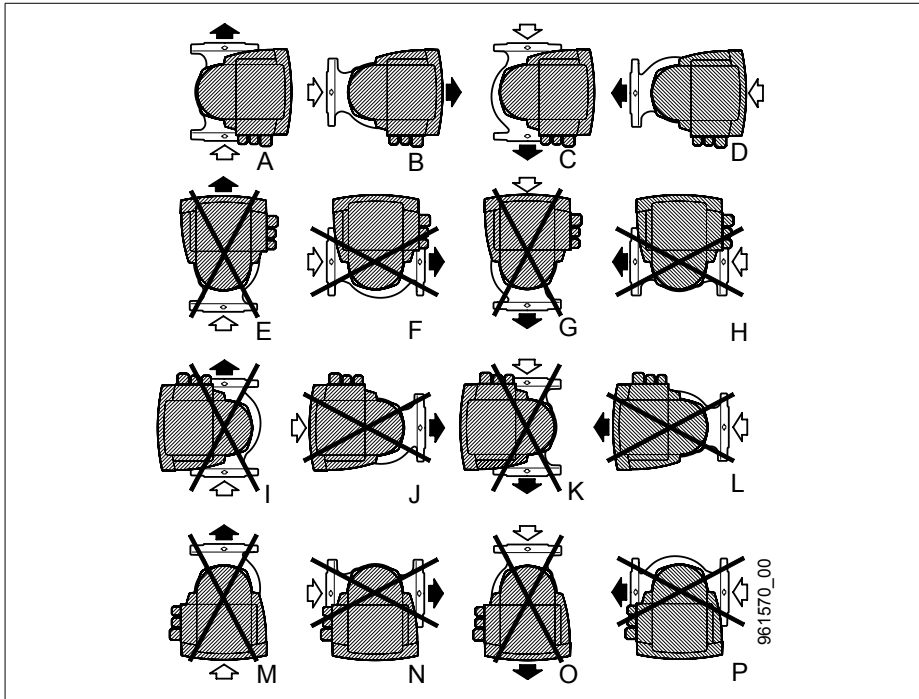

#### 4.5 Changing the installation position of the frequency converter

To ensure the correct installation position of the frequency converter, for installation positions E to P (see 4.4) the pump head must be rotated 90°, 180° or 270°.

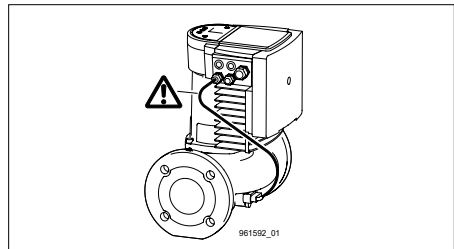
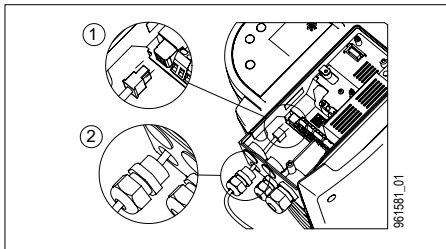

The sensor cable must be separated from the frequency converter in advance!



- ① Unplug the sensor cable
- ② Unscrew the cable screws

#### 4.5.1 Rotate the pump head ModuA M

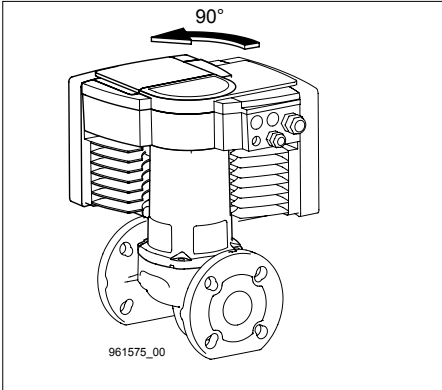

For pumps of a smaller design (P1 small 750 W) it is not necessary to take out the frequency converter, the pump head can be turned fully. The sensor cable must also be separated in advance from the frequency converter!

Turning the pump head **without** taking out the frequency converter:

#### ModuA Typ:

32F-12 220 40-8 220, 40-10 220, 40-12 250, 40-18 250, 50-6 240, 50-6 270, 50-8 240, 50-12 270, 50-18 270, 65-8 270, 65-8 340, 65-12 340, 80-8 360

#### 4.5.2 Rotate the pump head ModuA L

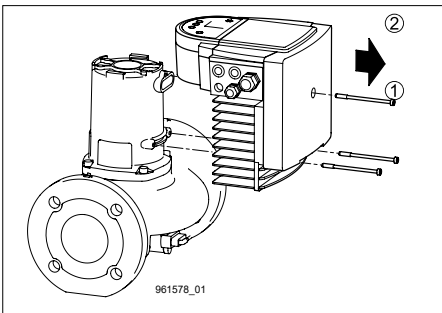

#### ModuA Typ:

65-15 340, 80-12 360, 100-8 450, 100-12 450

- ① Remove the three Torx screws
- ② Carefully pull out the electronics



#### Warning

Do not drop the disassembled pump parts!

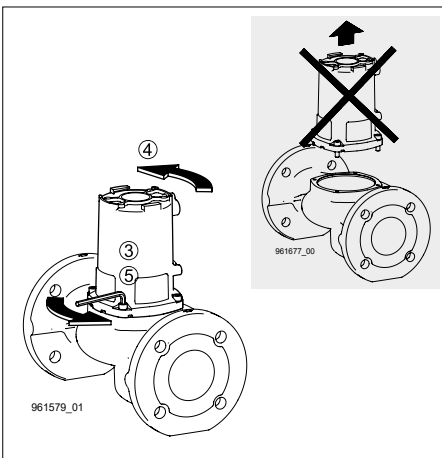

- ③ Remove the four inner hexagonal screws
- ④ Turn the pump head carefully to the position required **without lifting it from the pump casing**. (If the pump head is firmly connected to the pump casing, release the pump head using light blows with a rubber hammer).
- ⑤ Put in four inner hexagonal screws and tighten. (18Nm)

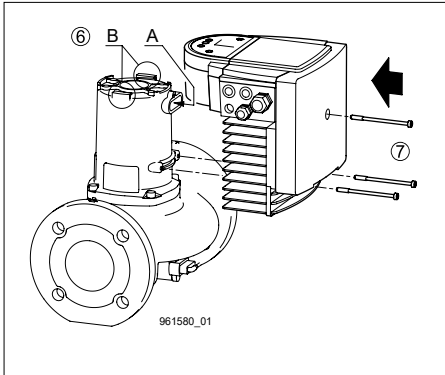

- ⑥ Carefully push in the electronics:  
«A»: connector plug  
«B»: Holder
- ⑦ Put in three Torx screws and tighten (8Nm)

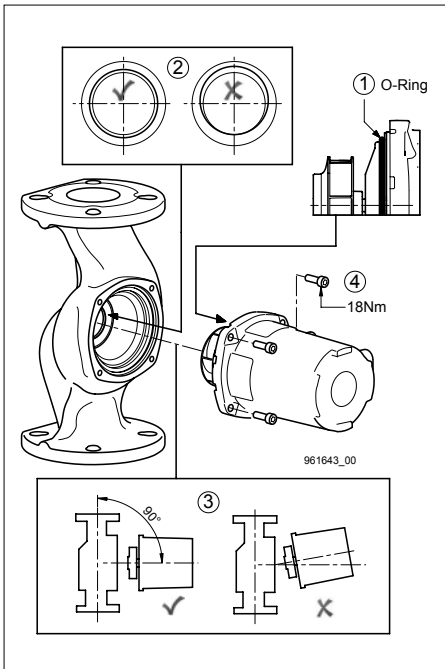

If the motor is lifted from the pump casing, care should be taken when replacing it due to the movable ring otherwise the impeller may be damaged.

- ① Ensure correct positioning of the O-ring.
- ② The ring in the pump casing must be centred again before fitting the motor.
- ③ Fit the pump head carefully so that the motor lies flat on the pump casing without any gaps.
- ④ Insert four hexagon socket bolts and tighten the screws. (18Nm)



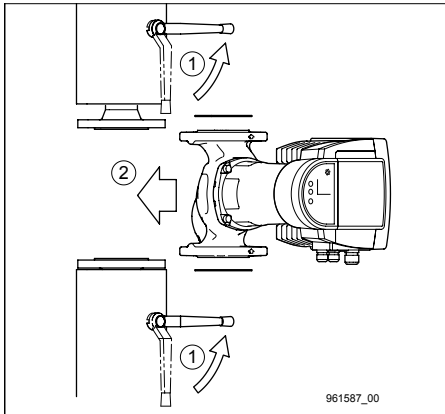

#### 4.6 Install the pump in the unit

- ① Close the shut-off valves and ensure that the system is without pressure when fitting the pump.
- ② Install the pump in the pipe with seals.



#### Warning

Risk of injury from escaping steam!

#### 4.6.1 Flange connection

The pump flanges are drilled with mounting holes, PN6/PN10/PN16. For safe screwing of the flanges, the shims supplied (B) must be fitted.



Safety elements (e.g. snap rings) are not permissible. For PN 10/16, special seals and screws must be used.



#### Warning

Use the relevant screws for nominal pressure PN.

	A		B		
	PN 6	PN 10/16	PN 6	PN 10/16	
<b>DN 32</b>	M 12	M 16	Ø 14	Ø 18	<p>961588_00</p>
<b>DN 40</b>					
<b>DN 50</b>					
<b>DN 65</b>					
<b>DN 80</b>	M 16	M 16	-	-	
<b>DN 100</b>					

Recommended screw tightening torque:

- for M 12 <40 Nm
- for M 16 <95 Nm

Installation of combined flange with combined flange is not permissible.

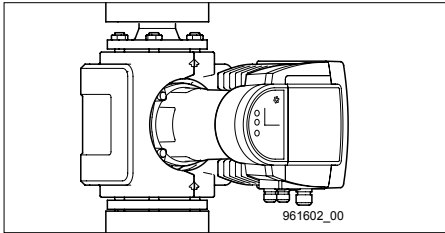

After installation is completed, put on the heat insulation shells and secure with cable bands.

## 5 Electrical connection

Electrical connection should be carried out in accordance with the local regulations. It is vital to ensure that the voltage and frequency indicated on the nameplate are compatible with the mains supply available.



### Warning

Before carrying out any electrical connection work, the voltage supply must be switched off.

The pump must be connected to an external network switch with a contact opening on all poles of minimum 3 mm.

The protection against indirect contact can be achieved by earthing or potential equalisation.

The pump does not require any external motor protection. The motor has integrated over-temperature protection, which offers safeguarding against overloading that appears slowly and against blocking according to IEC 34-11: TP 211.

### 5.1 Additional safety features

If the pump is connected to an electrical installation, which has an FI circuit breaker for additional protection, the FI circuit breaker must trigger with a pulsing direct current component if earthing fault currents arise.

The FI circuit breaker must be marked with the following symbol:

Symbol	Description
	Highly sensitive residual current circuit breaker type A in accordance with IEC 605
	Highly sensitive residual current circuit breaker type B in accordance with IEC 605

### 5.2 Supply voltage

1×230V ±10%, 50/60 Hz, PE

The voltage tolerances are set for equalising voltage fluctuations on the mains. They are not for operating pumps with voltages other than those shown on the nameplate.



With direct mains connection, the pump may not be switched on and off at the mains more than four times an hour. If the pump is switched on directly via the mains, it only starts after a 5-second delay.

### 5.3 Connection of the power supply

The pump must be protected on-site and must be connected to an external mains switch. All cables used must have a heat resistance of up to 85 °C. They must not be in contact with the pipe or the pump and motor casing. All cables must be connected in accordance with EN 60204-1 and EN 50174-2: 2000. The electrical connection must be made as indicated on the nameplate.

ModulA...	Nominal current [A]	Output P <sub>1</sub> [W]
ModulA 32F-12 220, ModulA-D 32F-12 220	0.17 – 1.51	15 – 329
ModulA 40-8 220, ModulA-D 40-8 220	0.19 – 1.23	18 – 264
ModulA 40-10 220, ModulA-D 40-10 220	0.18 – 1.60	18 – 352
ModulA 40-12 250, ModulA-D 40-12 250	0.17 – 1.93	16 – 423
ModulA 40-18 250, ModulA-D 40-18 250	0.17 – 2.70	16 – 600
ModulA 50-6 240, ModulA-D 50-6 240	0.20 – 1.16	21 – 247
ModulA 50-6 270	0.20 – 1.16	21 – 247
ModulA 50-8 240, ModulA-D 50-8 240	0.20 – 1.49	21 – 326
ModulA 50-12 270, ModulA-D 50-12 270	0.20 – 2.23	21 – 488
ModulA 50-18 270, ModulA-D 50-18 270	0.24 – 3.44	21 – 767
ModulA 65-6 270	0.22 – 1.58	23 – 355
ModulA 65-8 340, ModulA-D 65-8 340	0.24 – 2.06	24 – 450
ModulA 65-12 340, ModulA-D 65-12 340	0.23 – 3.36	25 – 759
ModulA 65-15 340, ModulA-D 65-15 340	0.27 – 6.08	30 – 1343
ModulA 80-8 360, ModulA-D 80-8 360	0.24 – 3.09	25 – 685
ModulA 80-12 360, ModulA-D 80-12 360	0.27 – 6.63	30 – 1476
ModulA 100-8 450, ModulA-D 100-8 450	0.28 – 4.85	30 – 1082
ModulA 100-12 450, ModulA-D 100-12 450	0.28 – 6.81	30 – 1551

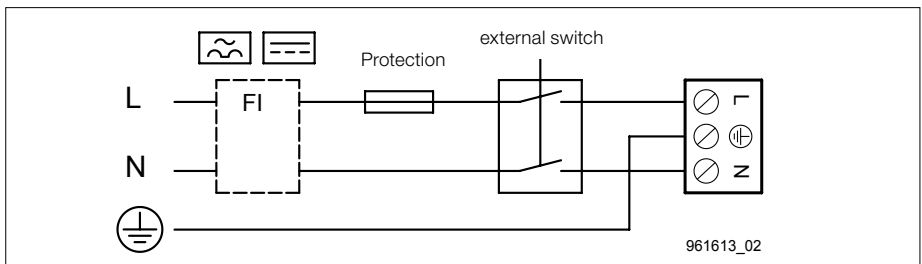

Example of a typical mains connection, 1x230V ±10%, 50/60Hz

5.4 Connection drawing Clamp description

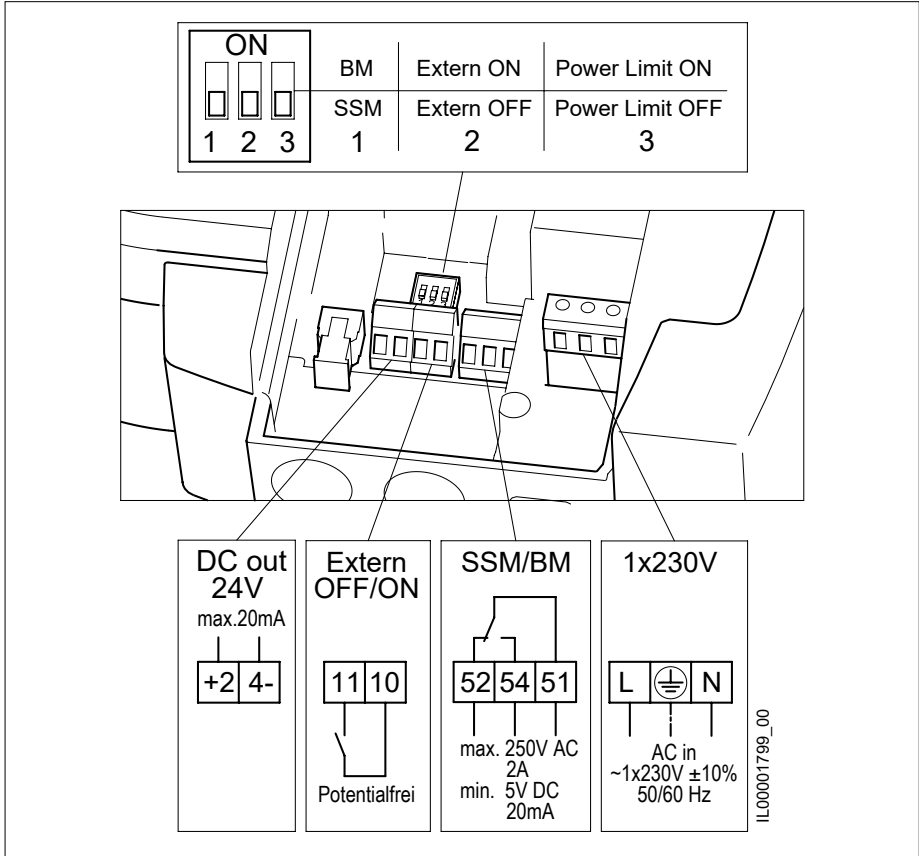

**Terminals:**

- +24-** DC out 24 V
- 11, 10** External OFF and external ON
- 52, 54, 51** Fault notification or operation notification
- L, N, PE** Mains connection, 1x230V +/- 10%, 50/60Hz













**Switch** (Bold lettering = as delivered)

- 1** **fault notification (SSM)** or operation notification (BM)
- 2** **External OFF** or external ON
- 3** **Power limit ON** or Power Limit OFF

## 5.5 Switch settings

### 5.5.1 Switch 1, Fault or operating signal (switchable)







The pump has a signal relay with potential-free changeover contact for external fault notification. The signal relay can be switched over to operation notification via switch 1.

		Connection	Status	Connection	Status
					
fault notification (SSM)	Switch 1 OFF		Impeller green <b>fault signal inactive</b>		Impeller green <b>fault signal inactive</b>
			Impeller red <b>fault signal active</b>		Impeller red <b>fault signal active</b>
operating notification (BM)	Switch 1 ON		turning impeller <b>operating signal</b>		turning impeller <b>operating signal</b>
			stationary impeller <b>operating signal inactive</b>		stationary impeller <b>operating signal inactive</b>

**5.5.2 Switch 2, external OFF or external ON (switchable)**

The digital input can be used for external ON/OFF switching of the pump. Using switch 2, it is possible to switch over from external OFF to external ON.

**Note:** If no external ON/OFF switch is connected, the pump runs if switch 2 is in the OFF position and no bridge is plugged in at terminals 11 or 10. This is the factory setting.

		Connection	Status	Connection	Status
<b>external OFF</b>	Switch 2 OFF 		operation ON		operation OFF
	Switch 2 ON 		operation OFF		operation ON

961828\_00

**5.5.3 Switch 3, power limit (can be activated)**

The power limit (volume flow limit  $\dot{V}$ ) can be activated in the pump.

The pre-set maximum volume flow is at the end of characteristic curve 3 (proportional pressure). The volume flow limit can be set from 25 ... 90 % via Biral Remote.

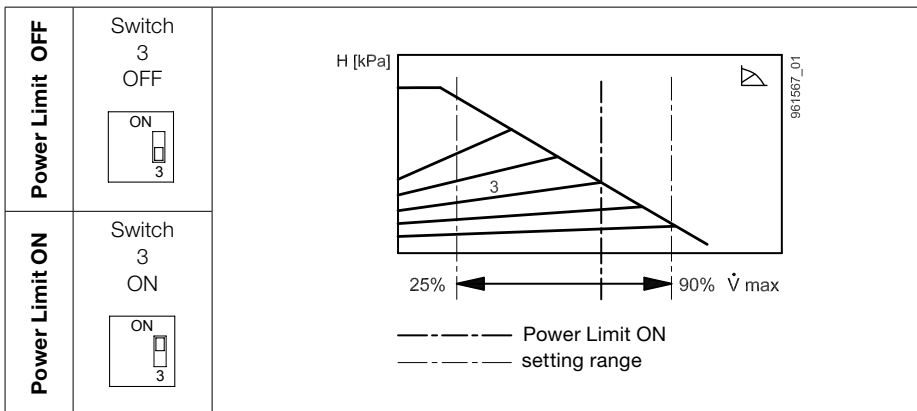

## 6 Start-up

### 6.1 General

Before start-up, it is vital that the unit is filled with the delivery medium and ventilated. Close to the inlet nozzles of the pump, it should also be the required minimum intake pressure. The system can be ventilated via the pump. The pump itself is self-ventilating.

### 6.2 Operational control

After switching on the power supply the pump must start up independently: the Biral impeller turns and flashes green.



The pump runs according to basic settings (see paragraph 7.10)

## 7 Settings



### Warning

There is a risk of burning! For high media temperatures the pump may become so hot that only the keys may be touched.

### 7.1 Control panel

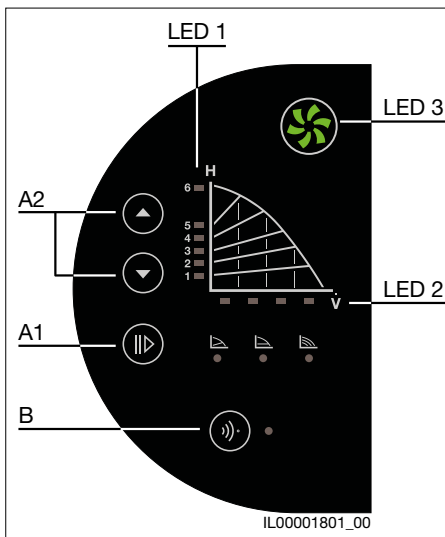

- A1** Control panel for setting the type of control (see para. 7.2)
- A2** Keys for setting (delivery height) with illuminated symbols (LED) to display delivery height and delivery flow, (see para. 7.3)
- LED 1** Display control curve characteristics set (phase)
- LED 2** Display the current delivery height  $\checkmark$  (25... 100%)
- LED 3** Biral impeller displays the status of the pump (see para 7.10)
- B** Bluetooth (see para 7.9)

### 7.2 Types of control

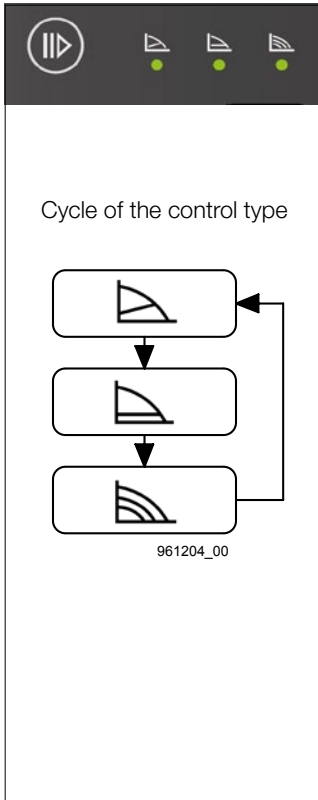

Operating key



**Controlled operation: proportional pressure (pp)**

- may be used in the following systems:
- Dual pipe systems with thermal valves and
    - long stretches of pipe
    - valves with large working area
    - high pressure loss
  - Primary circulation pumps with high pressure loss



**Controlled operation: constant pressure (cp)**

- may be used in the following systems:
- Dual pipe systems with thermal valves and
    - Delivery height >2m
    - Natural circulation
  - With very low pressure loss
  - Primary circulation pumps in systems with low pressure loss
  - Floor heating with thermostatic valves
  - Single pipe heating



**Non-controlled operation: constant speed (cs)**

The operating point can be optimally set by adjusting the speed (key A2) optimal. May be used for systems with constant volume flow: air-conditioning applications, heat pumps and boiler feed pumps, etc.

### 7.3 Delivery height (A2)

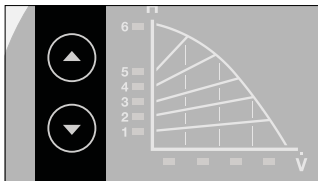

The target value of the pump can be set by pressing the key or .

Example:

LED 3 lights up (green): characteristic curve 3

LED 3 and 4 light up (green): characteristic curve between 3 and 4



If any radiators are not sufficiently hot, set the next highest characteristic line.



### 7.4 Display of the current delivery height (LED $\hat{V}$ )

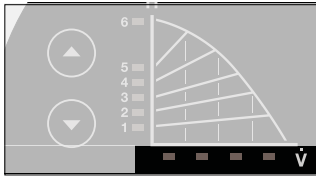



$\hat{V} = 25, 50, 75, 100\%$

### 7.5 Summary of maximum delivery height and delivery amount

ModulA...	$H_{\max}$ [m]	$V_{\max}$ [m <sup>3</sup> /h]
ModulA 32F-12 220, ModulA-D 32F-12 220	12	17
ModulA 40-8 220, ModulA-D 40-8 220	8	18
ModulA 40-10 220, ModulA-D 40-10 220	10	20
ModulA 40-12 250, ModulA-D 40-12 250	12	24
ModulA 40-18 250, ModulA-D 40-18 250	18	28
ModulA 50-6 240, ModulA-D 50-6 240	6	22
ModulA 50-6 270	6	22
ModulA 50-8 240, ModulA-D 50-8 240	8	25
ModulA 50-12 270, ModulA-D 50-12 270	12	32
ModulA 50-18 270, ModulA-D 50-18 270	18	37
ModulA 65-6 270	6	29
ModulA 65-8 270	8	34
ModulA 65-8 340, ModulA-D 65-8 340	8	34
ModulA 65-12 340, ModulA-D 65-12 340	12	44
ModulA 65-15 340, ModulA-D 65-15 340	15	55
ModulA 80-8 360, ModulA-D 80-8 360	8	48
ModulA 80-12 360, ModulA-D 80-12 360	12	66
ModulA 100-8 450, ModulA-D 100-8 450	8	59
ModulA 100-12 450, ModulA-D 100-12 450	12	67

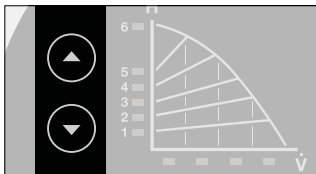
### 7.6 Activating/deactivating the control keys





By pressing keys  and  at the same time (for at least all function keys on the control panel are deactivated or activated).

### 7.7 START/STOP pump



Press to change the control mode to START or STOP  respectively (3seconds).

### 7.8 Activate/deactivate dry running detection

By pressing the button at the same time, ,  and  (for 10 seconds) the dry running detection is activated or deactivated.

1. Remove any BIM
2. Switch on pump
3. Ensure that the pump is not on «stop» operation
4. Make sure there is no current flow through the pump
5. Deactivate the key lock
- 6.

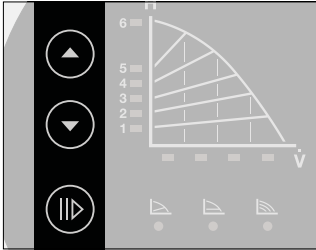

Press all three buttons for 10 seconds (10 seconds corresponds with 8–9 rotations of the impeller)  
A short interruption when pressing can lead to the key lock being switched on or the pump being switched to «stop» operation

7. If the impeller turns two segments, dry running operation is deactivated/if the impeller turns one segment, dry running operation is activated.
8. Module or external signals can be connected again.



If the pump is really running dry for deactivated dry running detection, it will not register an error and may run defectively.



Dry running detection can only be deactivated if the pump is running in fault-free operation and no Biral Interface Module (BIM) is plugged in.

## 7.9 Bluetooth (Biral ONE.)



Biral ONE. enables configuration and analysis of the ModulA. Wireless communication takes place via the integrated Bluetooth interface. Biral ONE. can be downloaded free of charge from Apple iTunes and the Google Play Store.

### 7.9.1 Activate Bluetooth



Pressing the button  activates Bluetooth.

### 7.9.2 Open Biral ONE.







### 7.9.3 Extract Biral ONE.

<b>Cockpit</b>	<ul style="list-style-type: none"> <li>- Pump type</li> <li>- Software version</li> <li>- Serial number</li> <li>- Manufacture date</li> <li>- Time</li> <li>- Delivery volume</li> </ul>	<ul style="list-style-type: none"> <li>- Delivery height</li> <li>- Medium temp.</li> <li>- Output</li> <li>- Speed</li> <li>- Control type</li> <li>- Target value</li> </ul>	<ul style="list-style-type: none"> <li>- Operating hours</li> <li>- Electr. energy</li> <li>- Switch 1</li> <li>- Switch 2</li> <li>- Switch 3</li> </ul>
<b>Konfiguration</b>	<ul style="list-style-type: none"> <li>- Control type</li> <li>- Type of operation</li> <li>- Target value</li> <li>- Control characteristic</li> <li>- Pump number</li> </ul>	<ul style="list-style-type: none"> <li>- Key lock</li> <li>- Time</li> <li>- Date</li> <li>- Power Limit</li> </ul>	
<b>Log</b>	<ul style="list-style-type: none"> <li>Alarm Log</li> <li>- Alarm 1</li> <li>- Alarm 2</li> <li>- Alarm 3</li> <li>- Alarm 4</li> <li>- Alarm 5</li> </ul>	<ul style="list-style-type: none"> <li>Warning Log</li> <li>- Warning 1</li> <li>- Warning 2</li> <li>- Warning 3</li> <li>- Warning 4</li> <li>- Warning 5</li> </ul>	





### 7.10 Biral impeller

Shows the status of the pump:

#### Normal operating mode

Example	Col-our	Move-ment	Oper-ating mode	Signal source	Output relay		
					BM	SSM	BrM
	green	turning	ON mode	- Pump - Remote	ON	OFF	ON
	green	still	STOP mode	- Pump - Remote	OFF	OFF	ON
	green	turning	ON mode	- Network	OFF	OFF	ON
	green	still	STOP mode	- Digital input - Network	OFF	OFF	ON

#### Warning

Example	Col-our	Move-ment	Oper-ating mode	Signal source	Output relay		
					BM	SSM	BrM
	red	turning	ON mode	- Pump - Remote	ON	OFF	ON
	red	still	STOP mode	- Pump - Remote	OFF	OFF	ON
	red	turning	ON mode	- Network	ON	OFF	ON
	red	still	STOP mode	- Digital input - Network	OFF	OFF	ON



#### Alarm

Example	Col-our	Move-ment	Oper-ating mode	Signal source	Output relay		
					BM	SSM	BrM
	red	still	Alarm	Alarm	OFF	ON	OFF

BM = operating signal / BrM = ready signal (BIM B3)

SSM = fault notification (Alarm)

### 7.11 On-site adjustment of the pump

	Proportional pressure, LED lights up green
	Control characteristic curve set at 3, LED lights up green
<b>Switch 1, OFF</b>	Fault signal, See para. 5.5.1
<b>Switch 2, OFF</b>	External OFF, See para. 5.5.2
<b>Switch 3, OFF</b>	Power limit OFF, See para. 5.5.3

## 8 Fault summary and checklist



### Warning

Before starting to rectify faults, it is vital that the pump is taken out of operation, and it must be removed from the mains at all poles and safeguarded from being switched on again. This should only be carried out by specialist staff.



Accessible voltage!



Risk of scalding from escaping medium.



Risk of burning from hot surfaces.

Use the Biral ONE app to read the faults via the Bluetooth interface.

### Biral Impeller does not light up

Fault	Remedy
No power supply	Check the mains switch and fuses Check the mains plug and cable

### Biral Impeller shows a warning

Warning codes (Warning)	Fault	Remedy	Detection without Biral ONE
Sensor communication fault (88)	The pump is receiving a signal from the integrated sensor that is outside the permissible range	Make sure that the electrical connector and cable are properly connected to the sensor. The sensor is on the rear of the pump body. Replace the sensor or contact Biral SERVICE.	1. Switch the pump to a constant speed (cs). If the warning no longer appears, there is a sensor communication error (88)
<b>Internal fault</b> – Memory access error (84) – FU parameter error (85)	Fault in pump electronics.	Replace the Electronics Modula or contact Biral SERVICE.	2. If the warning remains active, there is an internal fault.

### Biral Impeller shows an alarm

If the pump has no Bluetooth interface, go through the following list from top to bottom step by step.

Alert codes (Alert)	Fault	Remedy	Detection without Biral ONE
Low voltage (40, 75)	The power supply voltage to the pump is too low.	Make sure that the power supply is within the specified range.	1. Check the power supply
High voltage (74)	The power supply voltage to the pump is too high.		

<b>Alert codes (Alert)</b>	<b>Fault</b>	<b>Remedy</b>	<b>Detection without Biral ONE</b>
Turbine mode (29)	Other pumps or devices are causing a forced flow through the pump even when the pump is switched off/not running.	Check whether any non-return valves in the system have failed. Replace the non-return valves where necessary. Check whether the non-return valves etc. are fitted in the correct places in the system.	2. Switch off the pump by means of the master switch. If LEDs on the control panel are lit, the pump is running in «turbine mode».
Motor jammed (51)	The pump is jammed.	Remove the pump head (see instruction manual for ModulA motor) and remove any foreign objects or dirt that may be preventing the pump from rotating. Check the rotor and, if it is damaged, replace the ModulA motor; otherwise reassemble the pump (see instruction manual for ModulA motor).	3. Switch the pump off and on again by means of the master switch. Three seconds after mains ON, three unblocking attempts are made. The fault relay switches on and the Biral Impeller flashes red after 20 seconds.
<b>Internal fault</b> – Internal communication fault (10) – Hardware fault (72) – Starting current fault (155)	Internal fault in the pump electronics.	Check whether the pump's electrical connections are correct, and connect the pump correctly if necessary. Faulty signals or irregularities in the power supply can trigger alarm 72. Check whether a defective BIM (Biral Interface Module) is causing the fault by removing the module and starting the pump. Replace the BIM (Biral Interface Module) if necessary. Replace the ModulA electronics or ask Biral SERVICE for support.	4. If none of the preceding alarms apply, the issue is most likely an internal fault.
Temperature too high (64)	The temperature in the stator windings is too high.	Replace the ModulA motor or contact Biral SERVICE.	5. This alarm cannot be detected without Biral ONE.

## 9 Sensor

For maintenance work on the sensor or when changing the sensor, the Sealing cap must be placed correctly on the sensor casing.



### Warning

Before changing the sensor, the pump must be switched off and the system without pressure.

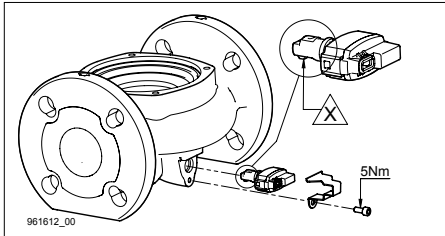

Nose must be facing downwards. Tighten the screw to affix the clamp at 5 Nm.

## 10 Accessories/versions

### 10.1 Biral interface module, BIM B3

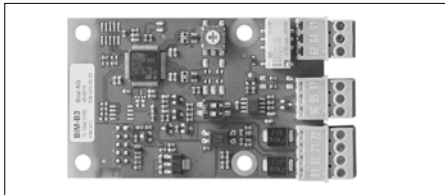

control module:

- self-regulating pumps
- external speed specification
- external specified setting
- Operating signal or ready signal (switchable)
- Alternating mode or reserve mode (switchable)

### 10.2 Building set for recessed installation of electronics

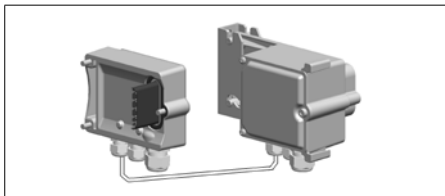

Media temperature up to +110 °C.  
Ambient temperature: max. 40 °C  
Pump can be insulated up to 100 °C media temperature operating instructions, see «Building set for wall installation» (0804412011)!

### 10.3 Cold water pump version



Pump with condensation-resistant colour paint in recessed design for use in air-conditioning units and heat pumps.

For use when condensation forms (media temperature lower than ambient temperature). See operating instructions, «ModulA GREEN» (0804392011)!

## 10.4 Blind flange

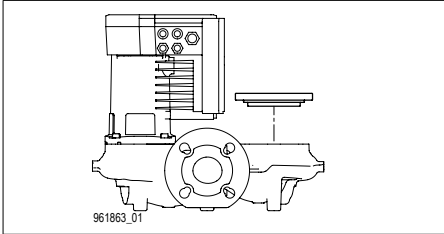

If a pump head from a dual pump is removed for repair, a blind flange can be used to close the opened aperture, to enable continued operation of the pump with the remaining pump head.

Biral item no.: 2205210150

## 11 Technical data

<b>Supply voltage</b>	1×230 V ±10%, 50/60 Hz, PE										
<b>Motor protection</b>	External motor protection is not required										
<b>Type of protection</b>	IPX4D (EN 60529)										
<b>Winding category</b>	Insulation category F										
<b>Temperature category</b>	TF110 (EN 60335-2-51)										
<b>Media temperature</b>	+15 °C bis +110 °C (ModulA... RED) +15 °C bis +85 °C (ModulA... BLUE)										
<b>Ambient temperature</b>	0 ° to 40 °C In transportation: -40 °C to +70 °C										
<b>Max. operating pressure</b>	The maximum operating pressure is given on the nameplate PN 6: 6bar PN 10: 10bar PN 16: 16bar										
<b>Noise</b>	The noise pressure level generated by the pump depends on the power consumption. <table border="1" style="width: 100%; border-collapse: collapse;"> <thead> <tr> <th style="text-align: left;">Pump size</th> <th style="text-align: right;">Max. noise pressure level dB(A)</th> </tr> </thead> <tbody> <tr> <td>40-4, 40-6</td> <td style="text-align: right;">39</td> </tr> <tr> <td>32F-12, 40-8, 40-10 50-6, 50-8, 65-6</td> <td style="text-align: right;">45</td> </tr> <tr> <td>40-12, 40-18, 50-11, 50-12 50-18, 65-8, 65-12, 80-8</td> <td style="text-align: right;">50</td> </tr> <tr> <td>65-15, 80-12, 100-8, 100-12</td> <td style="text-align: right;">55</td> </tr> </tbody> </table>	Pump size	Max. noise pressure level dB(A)	40-4, 40-6	39	32F-12, 40-8, 40-10 50-6, 50-8, 65-6	45	40-12, 40-18, 50-11, 50-12 50-18, 65-8, 65-12, 80-8	50	65-15, 80-12, 100-8, 100-12	55
Pump size	Max. noise pressure level dB(A)										
40-4, 40-6	39										
32F-12, 40-8, 40-10 50-6, 50-8, 65-6	45										
40-12, 40-18, 50-11, 50-12 50-18, 65-8, 65-12, 80-8	50										
65-15, 80-12, 100-8, 100-12	55										
<b>Leakage current</b>	The mains filter of the pump causes a leakage current to the earth of <3.5 during operation										
<b>Power consumption when pump switched off</b>	<3W										
<b>Performance factor cos-phi</b>	The ModulA has an integrated performance factor correction filter (PFC). This ensures that cos-phi is always between 0.98 and 0.99 and is therefore kept very close to the ideal value 1.										
<b>EMV (electromagnetic compatibility)</b>	EN 55014-1:2006, EN 55014-2:1997, EN 61000-3-3:2008 and EN 61000-3-2:2006										



## 12 Recycling

In the course of developing this product, particular attention was paid to sustainability. That also includes the disposal and recyclability of the materials. Thus the following guide figures for recyclability of components apply to all versions of the pump:

- 85% are recyclable
- 10% can be incinerated in a waste incineration plant
- 5% have to be disposed of at a land-fill site

This product and its components must be disposed of in an environmentally safe manner. Use the public or commercial recycling and waste disposal services.



### **Warning** **Magnetic field**

Risk of fatal or serious personal injury

- When dismantling this product, persons with a heart pacemaker must handle the magnetic materials in the rotor very carefully.



The symbol showing a waste bin crossed out indicates that the product concerned must not be disposed of as general household waste. If a product marked with that symbol has reached the end of its useful life, please take it to a suitable recycling centre. More information on the subject can be obtained from the appropriate local authorities. Separate disposal and recycling of such products helps to protect the environment and public health.

### 13 Spare parts list

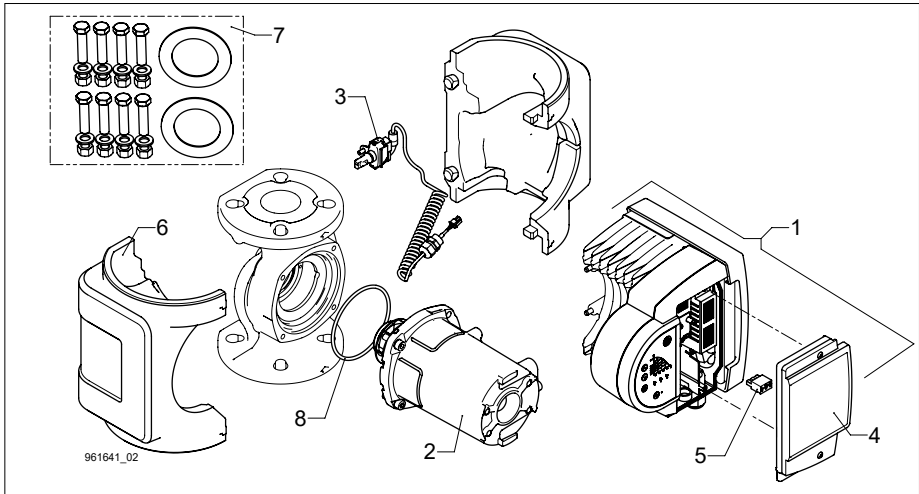

Biral item no.					
ModulA...	Pos. 1 Electronics with cover, neutral	Pos. 2 Motor with O-ring	Pos. 3 Sensor kit	Pos. 4 Cover with- out screws	Pos. 5 connector (L, N, PE)
32F-12	7000000421	7000000472	7000001071	Biral RED 2200330250  Biral GREEN 2200330350  Biral BLUE 2200330450	0591239750
40-8	7000000422	7000000473			
40-10	7000000423				
40-12	7000000424	7000000474			
40-18	7000000425				
50-6	7000000426	7000000475			
50-8	7000000427				
50-12	7000000428	7000000476			
50-18	7000000429	7000000477			
65-6	7000000430	7000000478			
65-8 270	7000000431	7000000479			
65-8 340					
65-12	7000000432				
65-15	7000000433	7000000480			
80-8	7000000434	7000000481			
80-12	7000000435				
100-8	7000000436				
100-12	7000000437				

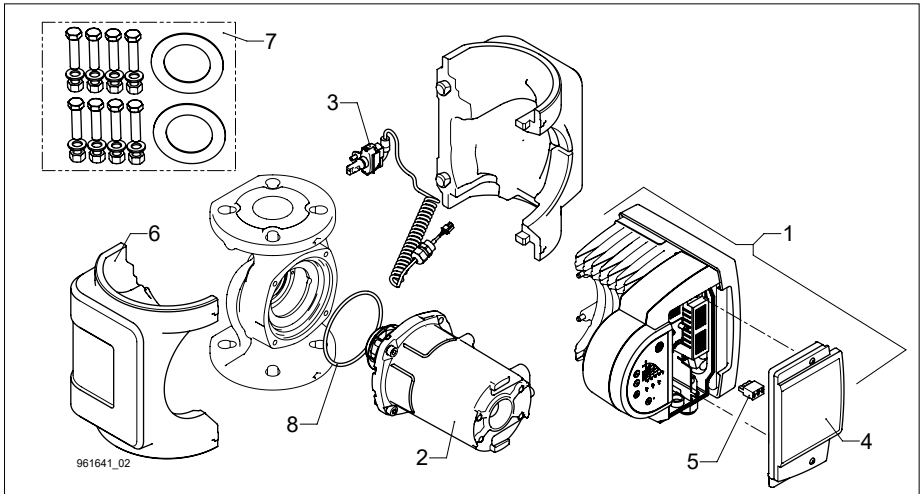

Biral item no.				
ModulA...	Pos. 6 Heat insulation shells	Pos. 7 Gasket and screw set	Pos. 8 O-ring	Changeover valve
<b>32F-12</b>	2201510150	0015034600	0525448450	2206710200
<b>40-8</b>		0015034300		2206710300
<b>40-10</b>				
<b>40-12</b>				
<b>40-18</b>				
<b>50-6</b>	2201520150	0015034400		
<b>50-8</b>				
<b>50-12</b>				
<b>50-18</b>	2201540150	0015034500		2206710500
<b>65-6</b>				
<b>65-8 270</b>				
<b>65-8 340</b>	2201550150	00 1503 0500		2206710700
<b>65-12</b>				
<b>65-15</b>				
<b>80-8</b>	2201560150	00 1503 0600		2206710800
<b>80-12</b>				
<b>100-8</b>	2201570150	00 1503 0600	2206710800	
<b>100-12</b>				

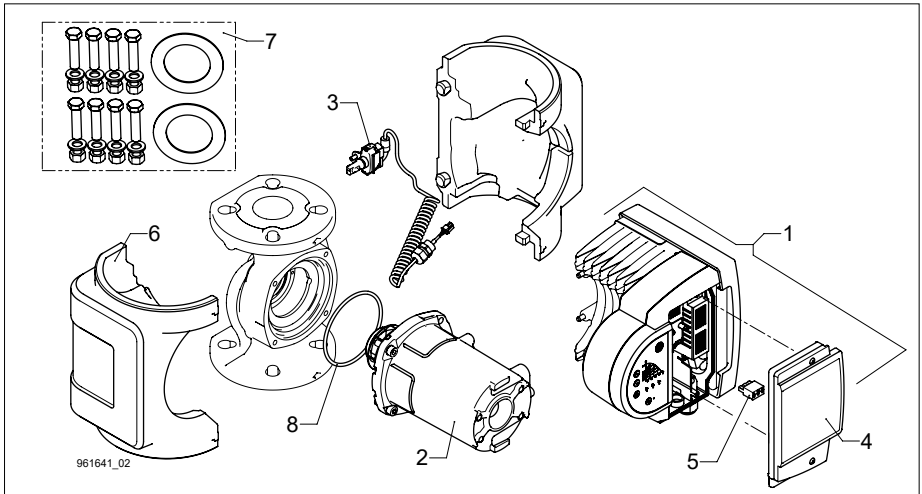

Número de artículo Biral				
Modula...	Pos. 6 Aislamiento térmico	Pos. 7 Juego de juntas	Pos. 8 Junta tórica	Tapa de conmutación
32F-12	2201510150	0015034600	0525448450	2206710200
40-8		0015034300		2206710300
40-10				
40-12				
40-18				
50-6	2201520150	0015034400		2206710400
50-8				
50-12				
50-18				
65-6	2201540150	0015034500		2206710500
65-8 270				
65-8 340				
65-12				
65-15	2201550150			
80-8	2201560150	00 1503 0500	2206710700	
80-12				
100-8	2201570150	00 1503 0600	2206710800	
100-12				

**Biral AG**

Südstrasse 10  
CH-3110 Münsingen  
T +41 31 720 90 00  
F +41 31 720 90 10  
info@biral.ch  
www.biral.ch

**Biral GmbH**

Kesselsgracht 7a  
D-52146 Würselen  
T +49 2405 408070  
F +49 2405 40807-19  
info@biral.de  
www.biral.de